

Understanding 'The Rainscreen Principle'

Presented by



December 14, 2006

Introduction

This document is supplied by the Metal Construction Association, a not-for-profit trade organization that practices education as one of its cornerstones. *Understanding 'The Rainscreen Principle'* is published as an attempt to clarify to the architectural and design community regarding the key principles and background information employed in **Drained/Back-ventilated** or **Pressure equalized** Rainscreen systems. It is also intended to be available as a resource to the General Contractor, Code Official or Owner communities to explain how the design properties of these two systems accomplish water infiltration management and prevention. Both systems employ open joinery and allow a certain amount of water into the cavity area between the outer and inner leafs. **Drained/Back-ventilated** systems rely on the ventilation cavity to both drain and dry-out the residual water. **Pressure-equalized** systems (PERS) employ drainable compartmentalization to limit water penetration during periods of pressure disequilibrium and to facilitate rapid pressure equalization. PERS greatly minimizes and under certain weather conditions can eliminate water in the rainscreen cavity.

Wall system designers' heightened concern for entrapped moisture and the related consequences, such as mold and metal corrosion, have increased the demand for Rainscreen Wall Systems which offer needed venting and drying potential while controlling rainwater. Since these wall systems are constructed from several inter-related components which must work together to obtain the stated performance standards, there is much confusion in the design and construction community about how these inter-related components should be specified, contracted and constructed. This document defines the nature of available metal-faced Rainscreen systems and their performance features.

The Metal Construction Association members are increasingly aware and concerned about the level of confusion and misinformation feeding the increased presence of 'Rainscreen/Pressure Equalized' metal-based cladding systems in the domestic commercial design and construction marketplace. If not corrected through education, this misunderstanding of the fundamental performance levels of various Rainscreen systems will result in many structures having water and air leakage failures which will inevitably be blamed on the system suppliers. Only when Rainscreen systems that are properly detailed and applied by the design professional and thoroughly designed,

tested and detailed by the systems supplier are established as the acceptable standard of quality for the industry will the threat of failure be dramatically diminished. As an extreme example, although all too common, Rainscreen systems should never be applied to horizontal or skyward sloping surfaces. The open joinery fundamental to all Rainscreen systems simply cannot be relied upon to deflect, control or avert the buildup of water on horizontal surfaces that is common with rain-producing weather events. Alternate means of water control are a must for these surfaces.

It should be noted that the performance of all Rainscreen systems, whether pressure-equalized or drained and back-ventilated, rely upon a properly selected, detailed and installed air/water barrier appropriate for the geographic area. It must also be recognized that in all air/water barriers, a certain level of imperfection will exist after installation and this reduced performance level must be recognized and introduced during testing procedures, such as it has been by AAMA 508-05 for the 'Voluntary Test Method and Specification for Pressure Equalized Rain Screen Wall Cladding Systems.'

It is in recognition of these industry conditions and the resulting concerns that MCA's Rainscreen Taskforce offers this document. MCA intends to lead the effort in educating industry professionals and systems suppliers so that the metal construction industry will maintain its long history of excellence and long-term performance levels for building owners.

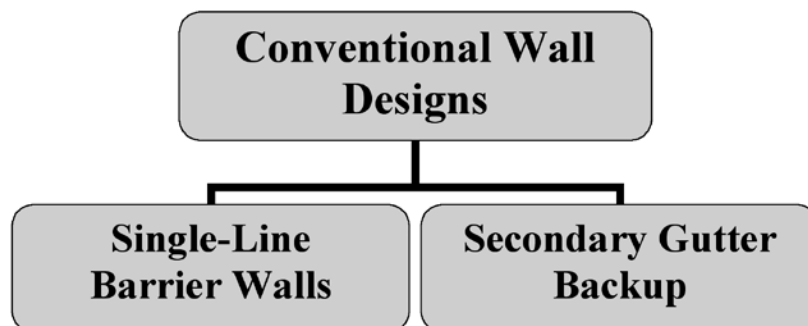

Conventional Wall Design:

A '**single-line barrier**' building skin acts as the "all-in-one" layer to keep out rain as well as to retain conditioned interior air and resist the forces of wind and air pressure. Based upon the design of the wall, a single-line barrier system can act as a vapor barrier and this condition should be considered in the wall design. The water-proofing of a single line barrier wall system relies upon the sealant integrity within the wall joinery and its long-term performance. Typically, single-line barrier systems, regardless of their design sophistication, perform only as well as the workmanship at the time of installation.

The '**secondary gutter backup**' wall recognizes certain limitations of the single-line barrier system; therefore a secondary drainage system is added behind and made integral with the 'single-line barrier' skin. The most common usage of this design technique has been in the aluminum and glass curtainwall industry. Here again, much of the long term performance for these systems

relies heavily on 1) resistance to the degradation of the internal seals and 2) quality workmanship during installation. Certain types of internal guttering systems are not easily accessible for maintenance once the system is fully assembled. If the internal gutters clog or seals break down, the backup is breached and water can migrate into the building. Once breached, major or complete disassembly is generally required (at major cost) to correct the guttering elements to acceptable performance levels.

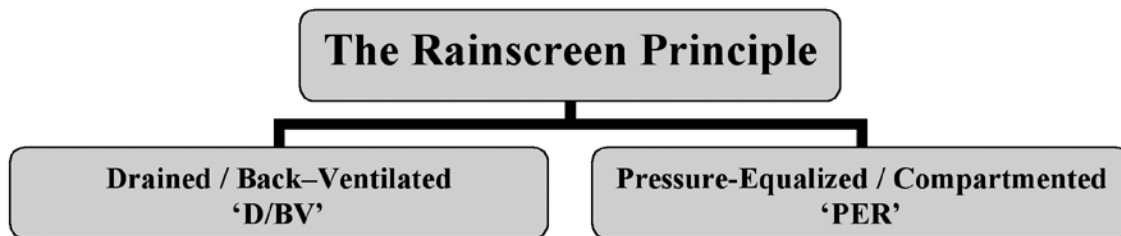

The 'Rainscreen Principle':

The 'Rainscreen' approach is based upon two separate and distinct barriers (or leafs) on the exterior building wall. The **outer leaf** sheds and controls (but does not eliminate) the majority of the rain water, while the **inner leaf** performs the multiple functions of 1) final moisture barrier, 2) air/vapor barrier, 3) insulation and 4) building structural wall. The outer leaf allows penetration of water through open joinery. The volume of penetrating water will vary dependent upon design principle. This is where the 'D/B-V' and 'PER' approaches become separate and distinct design concepts that should not be combined. Both use the principle of controlling water leakage, but not necessarily stopping water penetration through the exposed outer leaf. The inner leaf design is treated differently based upon the chosen approach. Unfortunately, the term 'Rainscreen' has been generalized and consolidated into one commingled product in specifications combining both systems' characteristics. To complicate and confuse matters, the air and water resistance criteria from the traditional single-line barrier systems have been applied to the design and specification of the exposed outer leaf. Placing air and water tightness criteria on the outer leaf contradicts the underlying fundamentals of 'the Rainscreen Principle.'

As JM Anderson and JR Gill have aptly stated in their book **Rainscreen Cladding: A Guide to Design Principles and Practices** ... "The Rainscreen approach to weather protection developed into two distinct techniques. First there is the drained and back-ventilated Rainscreen which involves draining off most of the rain water at the outermost surface of the wall and providing for cavity drainage and evaporation of the remainder. Second there is the pressure-equalized Rainscreen. Here the aim is to eliminate penetration through the Rainscreen not by tightly sealing joints, but by leaving some or all of them open to the passage of air **but not of water**. Both approaches can work successfully, but care must be taken that the two are not confused, since the adoption of hybrid versions can result in unsatisfactory performance."

Let's take a look at the two fundamental 'Rainscreen Principal' designs in more detail:

Drained / Back-ventilated (D/BV)

The D/BV employs ...

- 1) A series of sheets, panels, or planks (collectively called 'Cladding') fixed to vertical support channels or rails as the outer exposed leaf or barrier. Joints in the outer leaf are open but designed to obstruct water penetration by kinetic energy and wind force. It must be understood that the joinery is designed to minimize, not prevent water penetration. Water leakage resulting from variable wind-induced air pressure differentials will occur. Thus, at times, relatively large amounts of water can and will penetrate the outer leaf through its open joinery. Water is permitted to run down the interior face of the outer leaf cladding, but is controlled by the cladding design (vertical channels or rails combined with water head barriers in horizontal joinery which directs water flow to the vertical elements). Minor wetting of the inner leaf surface can occur and is permitted.
- 2) The series of vertical channels are designed to collect the penetrating water and drain it through gravity action and cross-directing at fenestrations and penetrations to the bottom and exterior of the outer leaf.
- 3) Fenestrations and system penetrations must be continuously flashed and detailed to collect and direct water to the outer leaf's exterior or re-direct the water into vertical drainage channels.
- 4) A cavity (or minimum allowable width of air space) between the outer and inner leafs is necessary to facilitate positive back-ventilation. This promotes rapid evaporation of any rain water deposited in the surfaces of the inner leaf or on the interior surfaces of the outer leaf. However, research has demonstrated that this cavity should be a minimum of 25mm (or 1") deep for brick or masonry veneer walls (in order to keep the cavity reasonably clear of mortar accumulation) and for other cladding materials a minimum of 10mm is recommended in order to promote proper ventilation action.¹ The cavity depth should be considered to be in addition to the depth of exterior applied insulation materials so as not to restrict the ventilation flow.
- 5) D/BV walls **require** an air/water barrier at the rear of the cavity, generally on the outer face of the inner leaf. This is because the inner leaf, by design, is allowed to be wet at times. The continuous air barrier serves to control airflow through the wall, reduces static air pressure differences across the cladding and by doing so allows the rainscreen cladding and second line of defense (the inner leaf) to perform more effectively. The inner leaf surface, in addition to having a water barrier applied, must be completely flashed to eliminate water penetration into the building and direct run-off of any water infiltration to the outer leaf.
- 6) The inner leaf is generally the structural building enclosure wall and thus can be constructed in variety of ways. It should be designed to envelop the buildings interior environment and be continuous in nature.
- 7) Water resistant insulation can be applied to the exterior side of the moisture barrier and is optional subject to the building's thermal design requirements. Use of insulation in this manner helps to maximize usable building space and rules out condensation and cold bridging to the inner face of the inner leaf.

- 8) Since D/BV Rainscreen systems are not pressure equalized (see the discussion below), the exterior leaf or cladding must be designed to withstand 100% of the building's wind load.

The main point: D/BV claddings are not designed to be watertight, and no deliberate attempt is made to minimize the structural or water penetrating effects of wind by pressure-equalization. Instead, the cavity behind the outer leaf is drained and positive back-ventilation is used to promote rapid evaporation of any rainwater deposited on the inner leaf surface. Additionally, conventional air and water test criteria cannot be applied to the outer leaf (due to its open joinery design), but should more properly be applied to the completed construction of the inner leaf.

Refer to **Figures 1** and **2** for representations of a D/BV rainscreen panel system's horizontal and vertical joinery. This example uses the European 'Hook & Pin' open joinery method which is a D/BV rainscreen system. Other joinery details can be employed under the D/BV theory of design and they do not need to be the 'Hook & Pin' type. Spline joinery systems certainly classify under this rainscreen design type, so long as continuous vertical drainage channels are employed and suitable bottom to top venting is provided for.

Key elements for Figures 1 and 2

- 1) The 'Outer leaf' cladding system (or the 'Rainscreen')
- 2) Vertical drainage channel
- 3) Penetration flashing
- 4) Ventilation cavity
- 5) Moisture barrier (commercial building wrap)
- 6) Approved 'Moisture Barrier' compatible flashing at all penetrations
- 7) The 'Inner leaf' or face of building structural wall
- 8) Optional moisture resistant insulation
- 9) The building structural wall

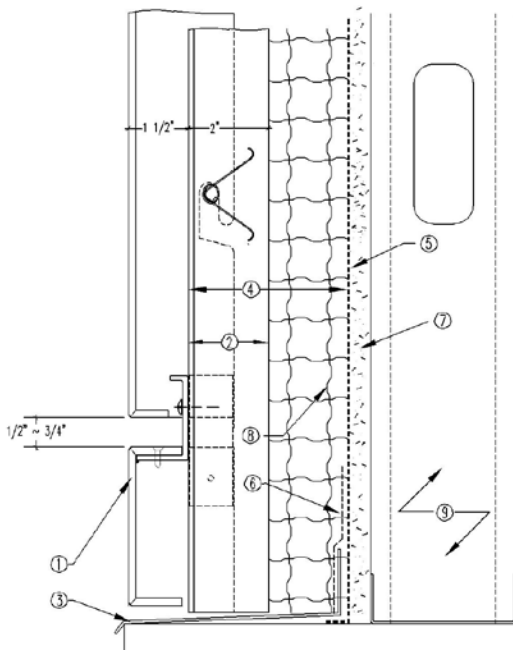

Figure 1: Typical horizontal joint detail for D/BV Rainscreen.

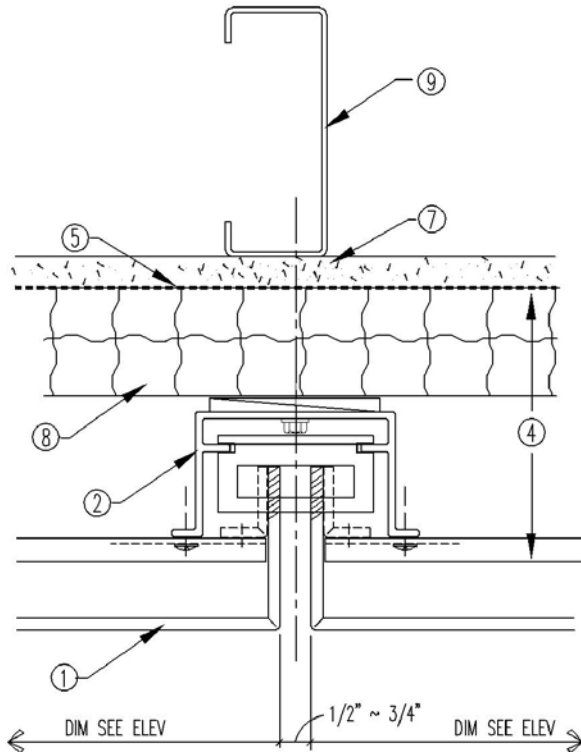

Figure 2: Typical Vertical joint detail for D/BV Rainscreen ('Hook & Pin') panel system.

Pressure-Equalized / Compartmented (PER)

Pressure-equalized Rainscreen walls are more design intensive. As such, they are also very sensitive to design variations and deviations from the PER design principles. The openings in the PER wall must be specifically designed to allow both static and dynamic pressure equalization to take place across the rainscreen. The essential defining attribute that differentiates PER from D/BV is the design and use of compartmentalization within the cavity. The reasoning for compartmenting is that pressure equalization can only occur within limited time periods if the internal volume of the cavity behind the Rainscreen is known and controlled. This compartmentalization is essential because wind pressures across a single face of a building are not uniform and are constantly changing. The number and geometry of the vent openings are calculated based upon the known cavity volume to allow sufficient air flow in and out of the internal compartmented space quickly enough to respond to ever-changing wind dynamics. This facilitates pressure differences across the plane of the rainscreen to be minimized vs. the internal compartment pressures thus equalizing the air-pressure on the external and internal sides of the exterior Rainscreen cladding element. If this condition exists, rain-driving forces are reduced, if not eliminated. The effective area of the vent holes depends upon 1) the air-tightness of the air barrier system on the inner leaf, 2) the stiffness of the rainscreen cladding and inner leaf and 3) the volume of the individual compartments that make up the internal air space. These compartments are an essential element of proper pressure-equalized design as they 1) control vertical and lateral air flow, 2) size the volume of the area that the vent openings must be designed to facilitate and 3) limit water infiltration and control water drainage at times of air-pressure disequilibrium. Non-compartmentalized cavities cannot be pressure-equalized.

A number of the system's construction elements are similar to the drained/back-ventilated rainscreen, but have several significant and important differences.

What is similar in both?

Refer to the D/BV outline above and Figures 1 and 2.

Elements (1), (3), (4), (5), (6) and (7) are common construction elements of the PER rainscreen.

However, item (4) the 'Ventilation Cavity' must be more specifically designed and controlled as to its size and volume in order to facilitate pressure-equalization. Item (5) the 'moisture barrier' must be an air/water barrier which can significantly deter air leakage into the building's interior thus cutting off air-pressure differentials that can bleed the ventilation cavity and reduce pressure equalization. . The design and installation of the air / water barrier must be a prime consideration in any rain screen system. The Air Barrier Association of America (abaa) has developed a master specification section 01410 "The Air Barrier System" that details the design considerations that must be addressed when specifying the air / water barrier to be installed. In order to insure a higher quality air barrier installation, but recognizing the likelihood of minor installation flaws, AMMA 508-05 details the minimum level of air leakage that the wall assembly must accommodate.

As noted in AAMA 508-05, at this point in time there is insufficient evidence to substantiate any reduction in the design load of the connection system and Rainscreen cladding elements for the PERS outer leaf system. If design load reductions are to be taken, it should be determined by the design professionals to what extent.

What is different?

Refer to Figures 3 and 4 below

The outer leaf cladding's (1) joinery design is altered to create extensions back to the face of the inner leaf (5) or insulation (7) creating 'pressure-controllable compartments' at both vertical and horizontal conditions. The size of the cladding and the compartmentation behind requires a series of special calculations that in reality must be proven-out by testing*. Each building has its own wind dynamics which must be taken into consideration so a "one-size-fits-all" approach is not recommended.

The vertical drainage channels (2) are typically interrupted by the bottom horizontal joinery of each compartmented unit. This is due to the fact that the principle design intent for a PER Rainscreen it to create isolated cladding units with internal cavities that self-drain any incidental water penetration.

The moisture barrier (5) must be a dual performing air and water barrier as discussed in "What is similar in both?"

Anderson and Gill note that for **Drained and back-ventilated rainscreens:**

"The main point to note about the drained and back-ventilated approach is that claddings are allowed to leak, and no deliberate attempt is made to minimize the effects of wind by means

of pressure equalization. Instead, the cavity behind the cladding is drained and positive back-ventilation is used to promote the rapid evaporation of any rainwater deposited on the inner leaf. The same process is used to evacuate the water vapour which permeates through the inner leaf and its insulating layer.”

Anderson & Gill further offer the following main point for **Pressure equalized rainscreens:**

“The main point to note about the pressure-equalized rainscreen approach is that without relying on the use of sealants or gaskets, every effort is made to minimize or eliminate leakage through the joints in the cladding assembly...There may, however, be some minor leakage into the cavity and a precautionary drainage mechanism is therefore necessary. Positive back ventilation is also used to promote the rapid evaporation of residual rainwater and to evaporate the water vapour which permeated through the inner leaf.”

Key elements for **Figures 3 and 4:**

- 1) The ‘outer leaf’ cladding system (or the ‘Rainscreen’)
- 2) Vertical drainage channel
- 3) Penetration flashing
- 4) Ventilation cavity/compartment
- 5) Moisture barrier (commercial air/vapor barrier)
- 6) Approved ‘Moisture Barrier’ compatible flashing at all penetrations
- 7) The ‘Inner leaf’ or face of building structural wall
- 8) Optional moisture resistant insulation
- 9) Ventilation path for pressure equalization and drainage
- 10) Horizontal air dam used to create compartmentalization
- 11) The building structural wall

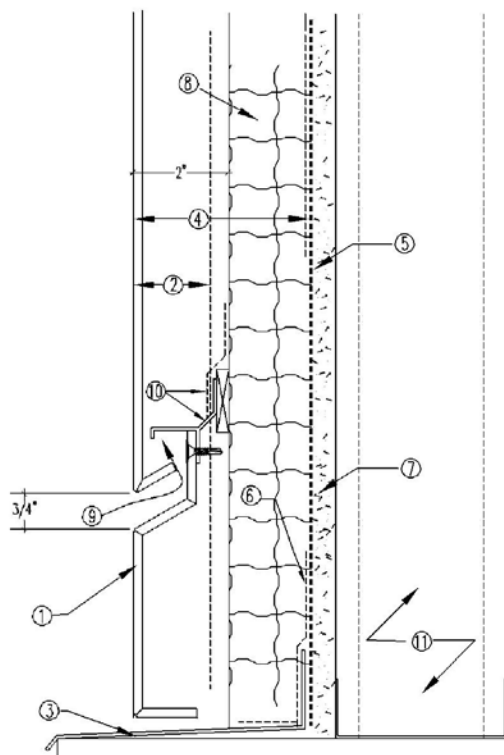

Figure 3: Typical horizontal joint detail for Rainscreen PE/C panel system.

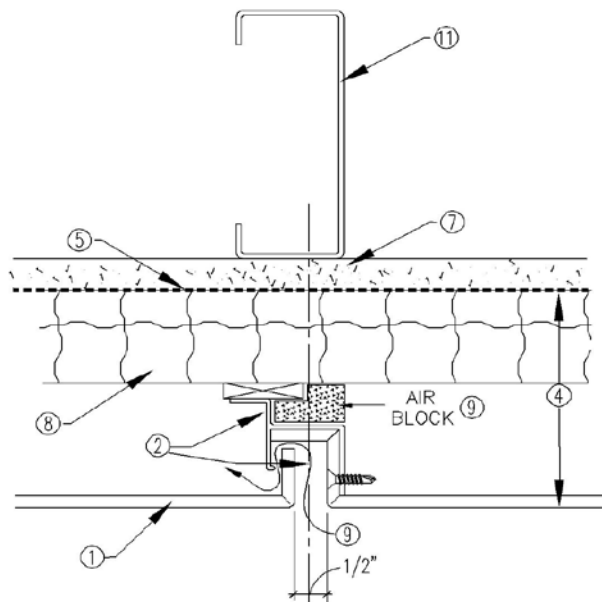

Figure 4: Typical vertical joint detail for Rainscreen PE/C panel system.

* One of the key elements of substantiating the existence of pressure equalization within a system is testing. While critical design calculations are a must for proper design, testing will prove the validity of these calculations. Up until recently, there has been no industry recognized testing protocol for proving-out pressure equalization. Some organizations create their own testing protocol while others side-step the issue due to lack of industry standards. AAMA has just released a test method which incorporates both cyclic and dynamic testing using air barriers with a defined level of imperfections. The AAMA 508-05 'Voluntary Method and Specification for Pressure Equalized Rain Screen Wall Cladding Systems' © 2005, dated December 2005 is the first recognized domestic testing protocol to be adopted specifically addressing Rainscreen performance. Copies of the testing procedures can be obtained (for a small fee) at www.AAMAnet.org (enter in search: '508')

Conclusion

There should be no confusion between the rainscreen types, yet confusion seems to be widespread in the industry. Too often we are faced with specifications that commingle the elements of both Rainscreen types and even introduce elements of other cladding designs. It must be incumbent upon us as professional representatives to educate the design market and to clear-up these misunderstandings.

As aptly stated by JM Anderson and JR Gill in their highly recognized technical article, ***Rainscreen Cladding: A Guide to Design Principles and Practice***: "Successful application in design, however, particularly as regards detailing, demands clear understanding of the scientific principles underlying the main approaches to rainscreen cladding ... Successful rainscreen design depends on proper understanding of both of the design principles and of the way in which the technology originated and developed ... confusion may lead to the development of hybrid versions, which may or may not achieve the design objectives."

In summation, there are two basic types of 'Rainscreen' systems—The Drained/Back-ventilated and the Pressure-equalized. Both systems employ open joinery and allow a certain amount of water into the cavity area between the outer and inner leaves. Drained/Back-ventilated systems rely on the ventilation cavity to both drain and dry-out the residual water. Pressure-equalized systems employ drainable compartmentalization to limit water penetration during periods of pressure disequilibrium and to facilitate rapid pressure equalization.

It should be well understood by the design and construction professionals that since the various 'Rainscreen principle' elements (outer leaf, insulation, air/vapor barrier and inner leaf) can likely be supplied by different sources/subcontractors specifications and contracting methods need to be closely coordinated and controlled to assure satisfactory performance of the integral system. Contractually, the overall warranty and performance of a Rainscreen wall must ultimately be determined by the design and construction professional. The open-ended and non-specific nature of many specifications issued on projects in the domestic market today are leading to confusion and reliance upon one source from one Rainscreen element (usually the 'outer leaf' supplier) to solve all function and performance criteria without requiring such responsibility specifically by specifications and/or contract. As much as inappropriate design and representation of a Rainscreen system by its supplier/manufacturer, the inappropriate specification and contracting of a Rainscreen system will ultimately lead to failure.

Footnotes:

1. NRC-CNRC Construction Technology Update No 9: Evolution of Wall Design for Controlling Rain Penetration© 1997, by G.A. Chown, W.C. Brown and D.F. Poirer. National research Council of Canada December 1997 ISSN 1206:1220

The design intent for the true 'Rainscreen' panel/cladding system is more clearly defined and discussed in a variety of reputable publications available through the internet and industry sources. Following is a short bibliography:

Primary source: American Architectural Manufacturers Association (1540 East Dundee Road - Suite 310, Palatine, IL 60067 (847)202-1350)

The Rain Screen Principle and Pressure-equalized Wall Design (AAMA Aluminum Curtain Wall Series) (copyright© 1996) [Note: The original article can be found in the Architectural Aluminum Manufacturers Association (AAMA - 35 East Wacker Drive, Chicago, IL 60601): Aluminum Curtain Wall Design Guide Manual, Volume 2 (copyright© 1979)]

Additional sources and references:

- Birkeland, "Curtain Walls," Handbook 11B, Norwegian Building Research Institute, 1962. Website: www.byggforsk.no/english.htm
- Garden, G.K., "Rain Penetration and Its Control," CBD40, National Research Council, Canada, 1963. Website: www.nrc.ca/
- Garden, G.K., "Joints Between Prefabricated Components," Proceedings of Seminar on Building With Prefabricated Components, Montreal, 1963.
- Garden, G.K., "Glazing Design," CBD55, National Research Council, Canada, 1964. Website: www.nrc.ca/
- Garden, G.K., and Dalglish, W.A., "Influences of Wind Pressures on Joint Performance." Technical Paper 264, National Research Council, Canada, 1968. Website: www.nrc.ca/
- Garden, G.K., "Look at Joint Performance," CBD97, National Research Council, Canada, 1968. Website: www.nrc.ca/
- Thermal and Moisture Protection Manual, for Architects, Engineers and Contractors, by Christine Beall, NCARB, CCS (copyright © 1999) McGraw-Hill
- NRC-CNRC Construction Technology Update No.9, Evolution of Wall Design for Controlling Rain Penetration, by G.A. Chown, W.C. Brown and G.F. Poirier (copyright © 1997) – National Research Council of Canada, Institute for Research in Construction www.nrc.ca/
- NRC-CNRC Construction Technology Update No.17, Pressure Equalization in Rainscreen Wall Systems, by M.Z. Rousseau, G.F. Poirier and W.C. Brown (copyright © 1998) – National Research Council of Canada, Institute for Research in Construction www.nrc.ca/
- NRC-CNRC Construction Technology Update No.34, Designing Exterior Walls According to the Rainscreen Principle, by W.C. Brown, G.A. Chown, G.F. Poirier and M.Z. Rousseau (copyright © 1999) – National Research Council of Canada, Institute for Research in Construction www.nrc.ca/
- Rainscreen Cladding a Guide to Design Principles and Practice, by JM Anderson and JR Gill, CIRCA (Construction Industry Research and Information Association) publications, 1988, London, England

Presented By: Metal Construction Association (MCA)
4700 West Lake Avenue
Glenview, IL 60025-1485

December 14, 2006 [R12]

© 2006 Metal Construction Association. All rights reserved.

Notes:

- 1) The illustrations in this document are conceptual in nature and are not intended to represent any manufacturers system. Any representation to the contrary is purely coincidental.
- 2) The information contained herein should not be used as a basis for reduction of the load-resisting characteristics of the outer leaf.
- 3) This document is meant to serve as a conceptual explanation and not a design guideline for Rainscreen systems.

MCA Rainscreen Task Force Members:

- J. David Clapperton, Principal / Corporate Treasurer / Executive Project Manager
The Miller-Clapperton Partnership, Inc., Austell, GA
- Bill Yannetti, Senior Manager ~ Technical Service
ALPOLIC Mitsubishi Chemical America, Inc., Chesapeake, VA
- Arthur “Chip” Pinkham, AIA, Director of Technical Services
RHEINZINK America, Inc., Cambridge, MA
- Keith D. Boyer, P.E., Director, Design and Development
CENTRIA, Moon Township, PA