

1 R4000 VERTICAL JOINT DETAIL
O400 SCALE: 3" = 1'-0"

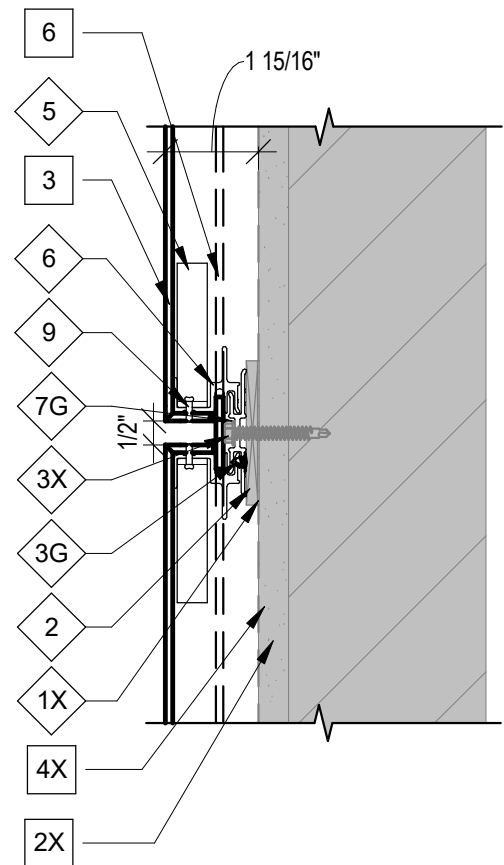

2 R4000 HORIZONTAL JOINT DETAIL
O400 SCALE: 3" = 1'-0"

.HARDWARE AND MATERIAL SCHEDULE

HARDWARE

1X	SELF-SEALING TAPE NOT BY CEI
2	1/4" SHIM BY CEI, REQUIRED
3B	#10-16x1" PFH TEK-3 BY CEI
3G	#6x3/8" WFH TEK-3 BY CEI
3N	SX3-D12 BI-MET BY CEI
3Q	TUF-S 6x9-A4 BY CEI
3R	LEVELING BOLT, 1/4"x5/8" BY CEI
3U	SX3-D10
3X	FASTENER NOT BY CEI
4	WEEP SCREEN
5	ALUM. CORNER KEY BY CEI, F.I.
6	ALUM. FRAME BY CEI, F.I.
7G	ALUMINUM WALL CLIP BY CEI
7K	ALUMINUM CLIP BY CEI
7L	C-PLANK CLIP BY CEI
9	POP RIVET BY CEI, F.I.
17	1" HAT CHANNEL BY CEI
17X	1" HAT CHANNEL NOT BY CEI

.HARDWARE AND MATERIAL SCHEDULE

18	2" Z CHANNEL NOT BY CEI
20	ALUMINUM RAIL
MATERIAL	
1X	INSULATION NOT BY CEI
2X	WEATHER RESISTANT BARRIER, NOT BY CEI
3	4MM MCM PANEL BY CEI, F.I.
4X	WALL CONSTRUCTION NOT BY CEI
5X	BACKER ROD & SEALANT NOT BY CEI
6	4MM MCM SPLINE BY CEI
11	HPL PANEL BY CEI
12	0.080" ALUM CLADLOK PANEL BY CEI

GENERAL NOTES

- 18 G.A. STRAPPING MAY BE REQ'D OVER DENSGLASS SUBSTRATE FOR PANEL ATTACHMENT.
- SEE DETAILS FOR FASTENER AND FLASHING SEALING PROCEDURES AS REQUIRED BY AIR BARRIER TYPE USED.
- ALL DIMENSIONS SHALL BE FIELD VERIFIED PRIOR TO FABRICATION.
- KEYNOTES REFER TO THE HARDWARE AND MATERIAL SCHEDULE. KEYNOTES MARKED WITH AN "X" ARE NOT SUPPLIED BY CEI.
- DIAMOND \diamond KEYNOTES REFER TO THE CORRESPONDING ID IN THE HARDWARE SCHEDULE.
- SQUARE \square KEYNOTES REFER TO THE CORRESPONDING ID IN THE MATERIAL SCHEDULE.
- "F.I." IN THE HARDWARE AND MATERIAL SCHEDULES IS AN ABBREVIATION OF "FACTORY INSTALLED".



800 East Duncan Street.
Manchester, MI. 48158.

phone: 734.212.3006 fax: 734.661.0360. design@ceimaterials.com

This document contains information proprietary to C.E.I. Materials, LLC. It is to be kept confidential and not applied, reproduced, used or conveyed to others without written authorization from C.E.I. Materials, LLC.

**R4000 ONLINE
TYPICAL DETAILS**

O400